

Synthesis Report 2017

Research Programme Controlled Thermonuclear Fusion

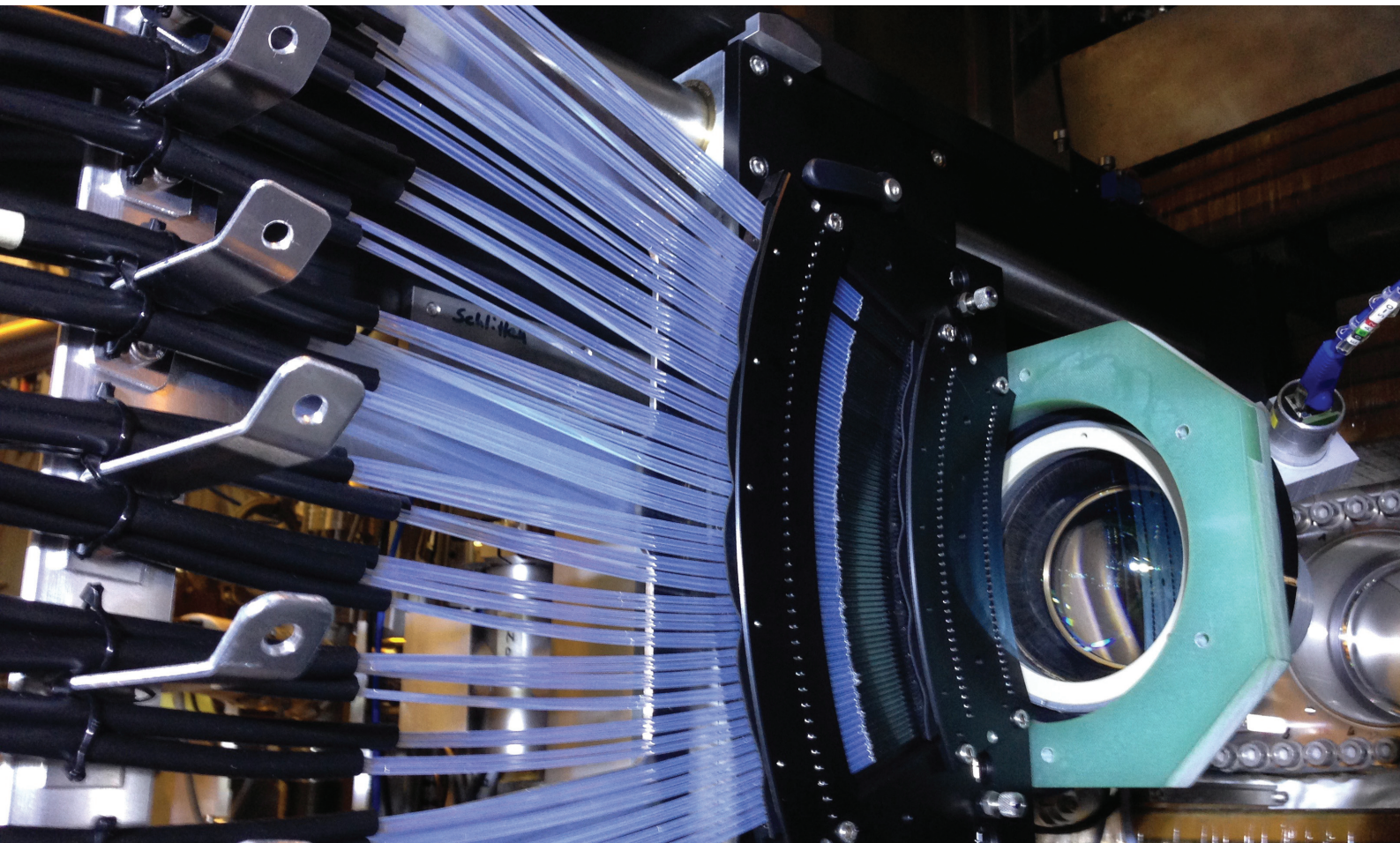

Schweizerische Eidgenossenschaft
Confédération suisse
Confederazione Svizzera
Confederaziun svizra

Swiss Federal Office of Energy SFOE

Cover page:

Thomson diffusion diagnostic on the TCV tokamak.

Research programme nuclear fusion

Annual report 2017

Editors:

Dr. Laurent Villard (SPC), Dr. Laurent Marot (University of Basel), Dr. Patrice Soom (SERI)

Programme manager:

Dr. Patrice Soom (SERI) (patrice.soom@sbfi.admin.ch)

<https://spc.epfl.ch>

The authors of this report bear the entire responsibility for the content and for the conclusions drawn therefrom.

Introduction

Nuclear fusion, the active process which takes place in a star's core, releases extraordinary amounts of energy. Developing the science and technology to enable the industrial and commercial exploitation of this type of energy-producing reaction is a huge challenge. If we are able to control nuclear fusion, it should be possible to generate huge quantities of energy with zero CO₂ emissions. The fuel required is available in large quantities and in many parts of the planet. Fusion reactors of the future will be intrinsically safe and the energy produced could be used for multiple purposes, including electricity generation and hydrogen production. About 100 years after decommissioning, all elements of the power plant should be non-radioactive and fully recyclable. This clean and safe source of energy would complement the renewable energy sources currently in use. The advantages of nuclear fusion motivate the international R&D effort

that addresses the major challenge of creating the extreme conditions necessary to initiate and sustain the fusion reactions.

From the outset, the European Fusion Research Programme has focused on developing nuclear fusion as a source of electricity. This strategy has been closely pursued by the European Atomic Energy Community Euratom for nearly 40 years, in particular since 1979, when the Joint European Torus (JET) was constructed and commissioned in the United Kingdom. The operation of this plant has been highly successful and has led to significant progress in controlling the deuterium-tritium fusion reaction in which an unprecedented fusion power of 16 MW, and an energy gain factor of $Q=0.65$ were achieved.¹

These developments led to the launch in 2007 of the international ITER Project by the European Union, the United

States, China, South Korea, Japan, India and Russia. The principal main objective of ITER is to demonstrate that nuclear fusion is technically feasible and a viable option for producing energy on an industrial scale. Currently under construction at the Cadarache site in France, ITER is designed to generate 500 MW of fusion power from 50 MW of injected power, i.e. to reach $Q=10$. Several of the same partners have also started to take steps towards the next stage after ITER, namely using nuclear fusion as a commercial source of power. They plan to design and construct a demonstration reactor capable of producing large amounts of power that can be fed into the existing electricity grid. In the European approach, this step, known as DEMO, will generate energy on the basis of nuclear fusion on an industrial and commercial scale. It could be operating by the 2040s.

Switzerland's role in international research into nuclear fusion

Swiss research into nuclear fusion is part of this European and international framework. Switzerland has been involved for a long time, principally through the work of the Swiss Plasma Center based at the Ecole polytechnique fédérale de Lausanne (EPFL) and the University of Basel, providing specific skills and expertise that are globally recognised.

Switzerland's involvement in international research into nuclear fusion goes back to the 2nd International Conference on Peaceful Uses of

Atomic Energy held in Geneva in 1958, at which it was agreed to declassify fusion research. Three years later, in 1961, Switzerland set up its own Plasma Physics Laboratory², becoming a pioneering nation in this field. In 1979 Switzerland became fully associated with the European Fusion Research Programme under a cooperation agreement with Euratom. Since 2014 Switzerland's participation in this research programme has taken place under an association

agreement with the EU's Framework Programmes for Research and Innovation that regulates both Switzerland's participation in the Horizon 2020 Framework Programme and the Euratom research programme until 2020, and the financing of the country's participation in the European Joint Undertaking for ITER and the Development of Fusion Energy, Fusion for Energy (F4E).

¹ Q is defined as the ratio between the power emitted in the reaction and the external power fed into the plasma by the reactor's heating system.

² Renamed the Plasma Physics Research Center in 1968 and Swiss Plasma Center in 2015. <http://spc.epfl.ch>.

IEA classification: 4.2 Nuclear Fusion
Swiss classification: 3.2 Fusion

Non-European developments

ITER

Internationally, activities in nuclear fusion research are currently focused on constructing the International Thermonuclear Experimental Reactor ITER. 2017 saw the application of a new operational and financial ITER plan adopted ad referendum by the ITER Council in November 2016. Under the reformed plan, ITER will come into operation in stages, with the first plasma scheduled for 2025 and the first major experiments being conducted from 2035.

Each member of the ITER Organization now needs to obtain a mandate from its national parliament to approve the new ITER baseline. The EU, which

hosts ITER, launched this process in June 2017 when the European Commission published a document³ for the attention of the European Council and European Parliament⁴.

In 2017 the ITER Organization focused on pursuing the reforms introduced in 2015 by the Director General Bernard Bigot in order to support the operational and financial management of this huge infrastructure project. 2017 was also a milestone in the construction of ITER, as 51.5% of all the tasks necessary to prepare the infrastructure to achieve First Plasma in 2025 were complete. 96% of the design tasks and 55.3% of the construction and manufacturing activities have been completed. The ITER Project is now progress-

ing rapidly towards the very complex machine-assembly phase.

Among the main developments in 2017 was the construction of the fourth storey of the imposing building that will house the tokamak. The latter will be installed inside the bioshield, a giant cylinder composed of concrete elements 3.5 metres thick and 30 metres high, which is now nearing completion. The equipment that will handle the massive components of the tokamak is already being installed in the assembly hall. The gigantic poloidal coils, which are too heavy to be transported, are also under construction at the Cadarache site. Components for ITER are being manufactured in all of the member states.

European developments

The priorities and strategic directions in European nuclear fusion research are set out in the European Fusion Development Agreement (EFDA) roadmap to the realisation of fusion energy⁵. This document describes the planned realisation of the ITER and DEMO projects, the aim being to demonstrate the feasibility of nuclear fusion for long-term use by 2050 and the possibility of providing large amounts of energy for the power grid. The roadmap also discusses physics research and the R&D activities regarding the technology required by ITER and DEMO. Furthermore, important sections of the roadmap are dedicated to the training of new generations of scientists and engineers. Although it focuses on the tokamak, the roadmap also supports the development of a different type of reactor architecture, the stellarator. DEMO).

At an institutional level, European research into nuclear fusion has a dual framework: the Euratom fusion research programme, currently being implemented by the EUROfusion consortium, and the European Joint Undertaking for ITER, Fusion for Energy (F4E), responsible for the EU's contribution to the construction of ITER.

EUROfusion consortium activities

The EUROfusion consortium has a budget of EUR 857 million for the years 2014 to 2018. Being a co-funded action, half of this is provided by the participants, the other half by Euratom. In October 2014 Euratom and EUROfusion signed a co-financing contract worth EUR 424.8 million, completing the process of restructuring the European Fusion Research Programme. As

a signatory of the Consortium Agreement establishing the consortium, the EPFL is an official member of EUROfusion. The University of Basel is affiliated as a linked third party. The activities of these institutions in 2017 under the EUROfusion umbrella are discussed in this report (see below).

The spectrum of R&D conducted under the auspices of the EUROfusion consortium covers the main elements needed for the roadmap for fusion energy, which is declined into eight main missions: the development of plasma regimes of operation, the heat exhaust systems, neutron resistant materials, the infrastructure needed for tritium self-sufficiency, the implementation of intrinsic safety features, the integrated design of DEMO, and the competitive cost of electricity from fusion power plants. The backbone of the medium

³ *Communication from the Commission to the European Parliament and the Council EU Contribution to a Reformed ITER Project (COM/2017/0319 final)*

⁴ *This was formally adopted by the European Council in April 2018, granting the Commission the mandate to formally approve the new baseline at an ITER Council ministerial-level meeting. It is hoped that the other ITER Organization members will soon move forward on obtaining the necessary mandate*

⁵ *EFDA roadmap to the realisation of fusion energy. <https://www.euro-fusion.org/wp-content/uploads/2013/01/JG12.356-web.pdf>*

term programme is the ITER device, but the present set of facilities, including the joint EU tokamak JET and the three national Medium Size Tokamaks, one of which is the EPFL TCV tokamak, as well as the proposed International Fusion Materials Irradiation Facility – Demo Oriented Neutron Source (IFMIF/DONES), are also considered as essential elements. Emphasis in the EUROfusion programme is equally put on theory and numerical simulations, and on education and training, an essential element of a trans-generational effort such as that of the quest for fusion energy. In 2017 a significant upgrade of the European fusion roadmap was conducted, taking into account the revised ITER schedule and the knowledge built in the last few years, in particular of the gaps that need to be filled before DEMO and the fusion power plant can be designed. The upgraded European fusion roadmap was released in 2018.

Fusion for Energy activities

In 2017, F4E activities focused on how the new baseline will affect the European contribution, the planning of which was restructured in the Straight Road to First Plasma project. With good operational performance, F4E had a commitment budget of EUR 563 million in 2017 and made record payments of EUR 860 million. 87% of this money covered F4E's contribution to the construction of ITER, i.e. all activities associated with construction at the Cadarache site. The construction of the buildings, in particular the complex housing the ITER tokamak, and the production of five of the nine sectors of the titanic vacuum chamber required close attention from F4E in 2017.

In addition to its activities focusing on ITER, F4E works closely with Japan in the Broader Approach, an agreement for research and development into nuclear fusion complementary to the ITER Project. Its aim is to achieve fusion energy more rapidly. The three main projects in the Broader Approach are the construction of the JT60-SA toka-

mak, the creation of the International Fusion Materials Irradiation Facility, IFMIF-EVEDA, and the establishment of an International Fusion Energy Research Centre, IFERC. In 2017 the JT60-SA in Naka (Japan) received its cryostat vessel body, and the LIPAc linear accelerator was commissioned at Rokkasho (Japan).

In its resolution of 27 April 2017, the European Parliament granted discharge to the director of F4E for the 2015 final accounts, confirming the progress made in F4E's management of the EU contribution to ITER in recent years. In 2016 the European Parliament decided not to grant discharge for the 2014 accounts for six months.

Finally, in 2017 F4E celebrated its tenth anniversary at the 39th meeting of its governing board. Among the high-ranking politicians present in Barcelona for the celebrations were European Commissioner M. Cañete, the Mayor of Barcelona A. Colau and the Spanish Secretary of State for Science, Development and Innovation C. Vela.

ITER, EUROPE AND SWITZERLAND

The construction of ITER continues at full speed. After ten years of the ITER Treaty, and of the establishment of the Domestic Agencies, including Fusion for Energy in Europe, of which Switzerland is a full member, more than half of the ITER infrastructure is now built. This important milestone confirms that the project culture introduced in the past few years is bearing fruit. The revised project baseline foresees the first plasmas in 2025 and the first high performance experiments with full fusion fuels in 2035. ITER is strengthening its links with the scientific and academic community using mechanisms such as the ITER Fellows program, the ITER Operations Network, and the International Tokamak Physics Activities. Members of our Center are at the forefront of all these initiatives. At the European level, a major effort of coordination and focusing of the program to be conducted in parallel to ITER is undertaken within the EUROfusion consortium, which operates on behalf of Euratom, to which Switzerland is associated. The European Roadmap to fusion energy is being revised and is set to become the new reference to all fusion R&D across Europe.





SWISS RESEARCH HIGHLIGHTS



Prof. Ambrogio Fasoli, Director of the SPC

Swiss fusion research is mainly conducted at the Swiss Plasma Center (SPC), directed by Prof. Ambrogio Fasoli, and at the Physics Department of the University of Basel. While the latter focuses specifically on interactions between plasma and plasma-facing components of tokamak systems, the SPC research covers a large spectrum of plasma-related activities, contributing to the two grand challenges of fusion, namely to demonstrate the feasibility of fusion energy on ITER and to complete the physics and technology basis of DEMO. It also exploits fusion and plasma spin offs for societal applications.

The SPC main experimental facility, the TCV tokamak, is set to play a major role worldwide, bringing major contribution to ITER realisation, DEMO conception and EUROfusion program implementation. Indeed, the TCV experimental campaigns are partly conducted and supported by Eurofusion, contributing to a significant financial return to Switzerland. In 2017, TCV ran 774 successful plasma discharges for Eurofusion, 1436 for the domestic campaign. The resulting rich scientific output embraces areas that can be explored uniquely thanks to its extreme flexibility, such as doublet plasmas, innovative divertor configurations or the influence of plasma shape on turbulence. It also includes areas that are investigated in synergy with the basic device TORPEX.

These studies benefit from the recently installed capability of heating the ion population directly using neutral beams, the first step of the TCV heating upgrade project, which will be completed in 2019 with the installation of four new gyrotrons. TCV upgrades also include the installation of the in-vessel baffles that create an exhaust chamber of variable closure, to investigate divertor configurations and regimes of interest for DEMO, as well as new diagnostic systems allowing a complete characterization of these configurations. The design of all of these elements has been significantly advanced in 2017.

The final steps of the ITER conductors tests are taking place on SPC site at Paul Scherrer Institute, in parallel with studies of high temperature superconductors, for DEMO and for the new generation of particle accelerators. Last year, an international team has been created to design the new version of the EDIPO test facility, which will produce a 15T magnetic field over a region of more than a meter, addressing the needs of high-energy physics and fusion communities. Finally a significant contribution to the preparation of ITER operation and DEMO physics development through its numerical simulation activities.

In parallel, several plasma applications for industry and society were investigated in 2017, with SPC spin offs active for example to reduce the pollution in large freight ships, or to fabricate high precision components for high frequency microwave technologies. An important event was the initiation of a novel bio-plasma laboratory, whose initial focus is the issue of sterilization, addressed in collaboration with local companies and the EPFL Life Sciences Faculty.

Rather than giving an exhaustive list of all progress made, the following pages presents a selection of 2017 research highlights at the Swiss Plasma Center and the University of Basel. These are presented by the respective heads of the responsible research units. As SPC Director Prof. Ambrogio Fasoli emphasizes, behind each of these achievements there are teams of physicists, supported by strong technical and administrative staff, without whom success would not have been possible.

TCV Tokamak



The TCV Tokamak is a thermonuclear fusion experimental device and the flagship facility of the Swiss Plasma Center. The device is operated partly as a shared European facility under the auspices of

the Medium-Size Tokamak Work Package of the EUROfusion consortium, with the participation of over 100 international scientists in 2017. Ample operation time is also available to internally-organized experiments, including extensive research for PhD dissertations. Research topics range from preparations for the operation of ITER, to development of advanced concepts for a future DEMO device, to curiosity-driven fundamental investigations. Dr **STEFANO CODA**, Maître d'Enseignement et Recherche (MER, Senior Scientist), is leading the TCV operations and is exposing below what the main findings of this research were in 2017.

Reactor designers list disruptions as their top concern. These are violent instabilities that terminate the discharge and can release energy in uncontrolled ways that can compromise the integrity of the device. Disruption mitigation or avoidance techniques are a must for ITER and are accordingly being developed and studied in TCV. In particular, the use of electron-cyclotron heating to prevent or stabilize the instability has been thoroughly documented, while a disruption database was constructed to aid the controller development.

Highly energetic “runaway” electrons are often generated by the disruptive instabilities and constitute an additional concern associated with them, as they can also damage the device wall. Techniques for electromagnetic control of the runaway beams have been explored in 2017, in addition to the use of noble gas injection to dissipate them.

The plasma shape planned for ITER was emulated in TCV in the baseline ITER regime, the so-called high-confinement mode (H-mode) with regular ELMs - periodic events that regulate the plasma density and stored energy.

The H-mode derives its good confinement by the presence of a transport barrier at the edge, which insulates the plasma from the exterior, creating a pedestal in the plasma pressure. The properties of the pedestal and their variation in response to gas injection - which is required for fueling and control - were investigated extensively in TCV in 2017.

So-called Advanced-Tokamak scenarios, characterized by high fractions of externally injected or internally generated plasma current, are explored to free the tokamak from reliance on a transformer and approach the realm of continuous operation. These scenarios were studied for the first time in TCV with joint neutral-beam and electron-cyclotron heating and current drive, with no transformer action in steady state.

As neutral-beam heating is still a comparatively new tool for TCV, fundamental studies of the basic physics associated with it are underway. These focus primarily on the dynamics of fast ions generated by the ionization of the energetic beam neutrals. Measurements suggest that these ions are subject to enhanced transport from plasma turbulence.

Turbulence - which is believed to be at the root of most plasma transport - has itself been the subject of extensive investigations, focusing in particular on its dependence on the plasma “triangularity” (a parameter quantifying the resemblance of the plasma to a D-shape, which uniquely in TCV can even be negative, i.e., a reversed D-shape). Transport is known to be stronger with positive than negative triangularity, and the plasma is indeed found to be more turbulent in the former case, over a large fraction of the plasma volume. An additional finding has come from studying the so-called Geodesic Acoustic Mode, a plasma oscillation related to phenomena that regulate turbulence: it has been shown for the first time to be associated with oscillatory particle flow to the wall, providing new insight into its fundamental properties.

Understanding the physics mechanisms of tokamak plasma exhaust - the processes by which energy and particles leave the confined volume - is essential both for optimizing the overall performance and for protecting the vessel wall from excessive heat loads. Studies of edge transport, turbulence, and heat flux behavior have been vigorously pursued in TCV in 2017 in a panoply of regimes (low and high confinement, edge plasma detached or not from the wall) and magnetic-field topologies, including those of interest for ITER and for DEMO. The dependence of the heat flux on triangularity was also documented.

Real-time control of a variety of plasma parameters is now possible thanks to modern control techniques, and the next challenge is to integrate the different controllers into a coherent ensemble. Considerable progress was made on this front in 2017, with density, shape, stored energy, macroscopic stability and current profile all controlled simultaneously within a supervisory platform ensuring the most efficient use of the finite resources available.

DISRUPTIONS



Sometimes, the plasma in a tokamak “disrupts”, i.e. there is an abrupt termination of the plasma discharge, which has its origin in various types of instabilities. Disruptions are a critical issue for present and future tokamaks due to their potentially

destructive consequences. Disruptions are capable of melting the divertor through thermal loads, breaking apart the vessel through electromagnetic loads and creating runaway electron beams that can cut through the vessel wall. Current research is focused on three subtopics to handle this issue (disruption prediction, avoidance and mitigation) with the final goal of combining these subsystems into a complete disruption handling system. Dr **Umar Sheikh**, Post-Doc at the SPC, describes the major progress achieved in 2017.

Significant advances have been made in the past year on the TCV tokamak to utilize new tools to study large numbers of disruptive discharges with the goal of enhancing predictive capabilities. Scenarios with ITER relevant disruptive events have been developed and techniques to identify the disruptive chain and act to restore normal plasma operation or produce a safe shutdown have been developed and implemented. An example of this work is shown in Figure 1, where a particular instability, called “Neoclassical Tearing Mode”, (NTM) is destabilized through an impurity influx and causes the plasma to disrupt and be lost in a few milliseconds. An example of no action, leading to a disruption, and two discharges with the application of the disruption handling system developed leading to safe shutdowns are presented in the Figure below.

As ITER will rely significantly on electron-cyclotron heating using microwaves, predicting the effect of turbulence in a reactor-scale environment on the propagation of microwaves is of paramount importance. Systematic measurements of these effects are underway in TCV, and results in 2017 have indeed confirmed a correlation between power transmission fluctuations and plasma density fluctuations.

TCV is currently the only tokamak in which the so-called “doublet” configuration - a figure-of-eight topological arrangement - can theoretically be created. This is a concept suggested and initially investigated, unsuccessfully, in the 1970’s, with the promise of increased performance with a higher macroscopic stability margin. Modern control technology has revived this possibility and a successful doublet was achieved in 2017 in TCV with plasma current up to 260 kA. While steady state has not yet been obtained, data suggest the appearance of a transport barrier in the mantle just outside the primary figure-of-eight boundary.

1 Gyrotron power (top), stored plasma energy (middle), plasma current (bottom). The green and blue curves correspond to two cases with disruption avoidance control, the red curve without.

2 Windowed Fourier spectra of MHD activity for discharges with the avoidance control system (top and middle) and without (bottom).

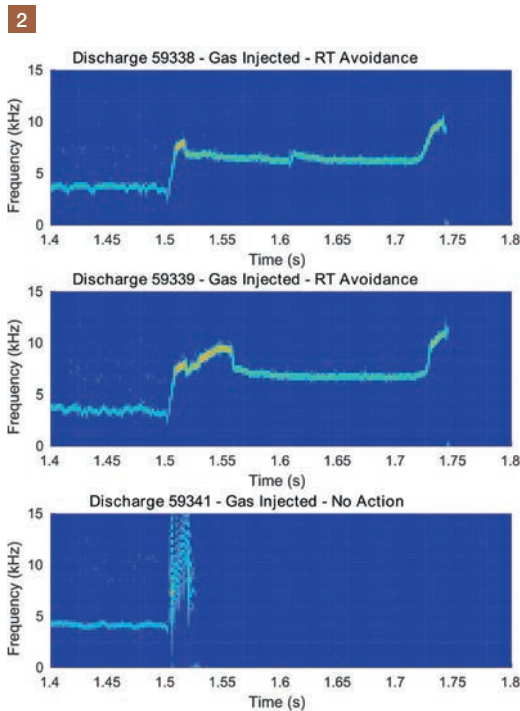
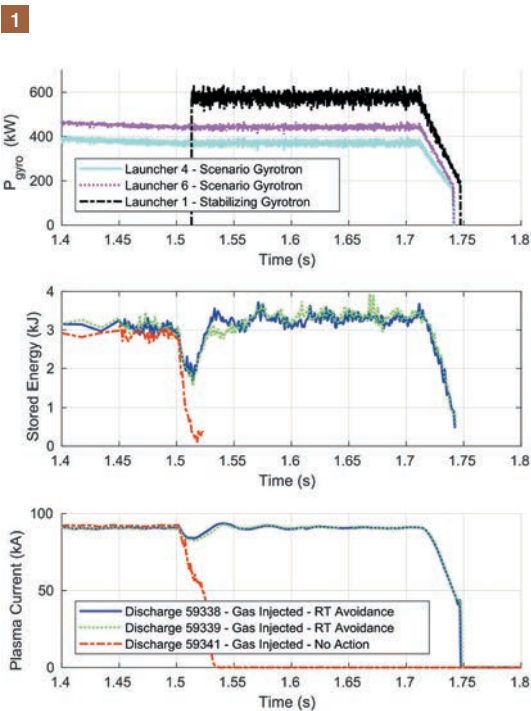

A TOKAMAK IN GOOD SHAPE - REDUCES TURBULENCE AND IMPROVES CONFINEMENT



Matteo Fontana, PhD student at SPC under the supervision of Dr Laurie Porte and Prof. Ambrogio Fasoli, was awarded the “Kyushu University Itoh Project Prize” at the 2017 EPS Conference on Plasma Physics for his research, which focuses on the measurement of turbulence in the plasma core using millimeter waves emitted by the plasma, using a diagnostic method called “correlation-ECE”. His work is applied to help us understanding the reasons behind a surprising finding on the TCV tokamak: by changing the plasma shape from a normal “D” to a reversed “D”, confinement is observed to improve by a factor of about 2. Normal “D” is referred to as “positive triangularity”, or “ $\delta < 0$ ”, and reversed “D” as “negative triangularity”, or “ $\delta > 0$ ”. These studies were made possible thanks to the unparalleled shaping capabilities and versatile heating systems of TCV.

The main results of this work can be summarized as follows. First, as shown in Figure 1, the improvement in quality of confinement, measured by the so-called “H-factor” (the higher, the better), for reversed “D” shapes persists throughout a very broad parameter range. This includes the electron to ion temperature ratio, T_e/T_i , the collisionality ($\nu_{\text{eff}} = 0.1R Z_{\text{eff}} n_e/T_e^2$), and the total heating power.

Second, temperature fluctuations measured using the correlation ECE diagnostic, Figure 2, showed that reverse-“D” shape reduces fluctuations across the whole explored parameter range, and that this reduction in fluctuations is clearly correlated to the improved confinement.

This work has a strong potential impact. Most importantly, the range of parameters explored in these experiments includes regions of interest for future, large reactor-like tokamaks, namely low collisionality and T_e/T_i close to 1. In these conditions, negative triangularity was seen to strongly suppress fluctuations leading to significantly improved confinement. If these observations will be found to scale well with machine size, they could become a strong argument in favour of reverse-D-shaped tokamaks as an alternative design for future reactors. Moreover, these results were obtained in so-called “L-mode” of operation, which avoids the potentially dangerous Edge Localized Modes (ELMs) in the “H-mode” of operation currently foreseen in ITER.

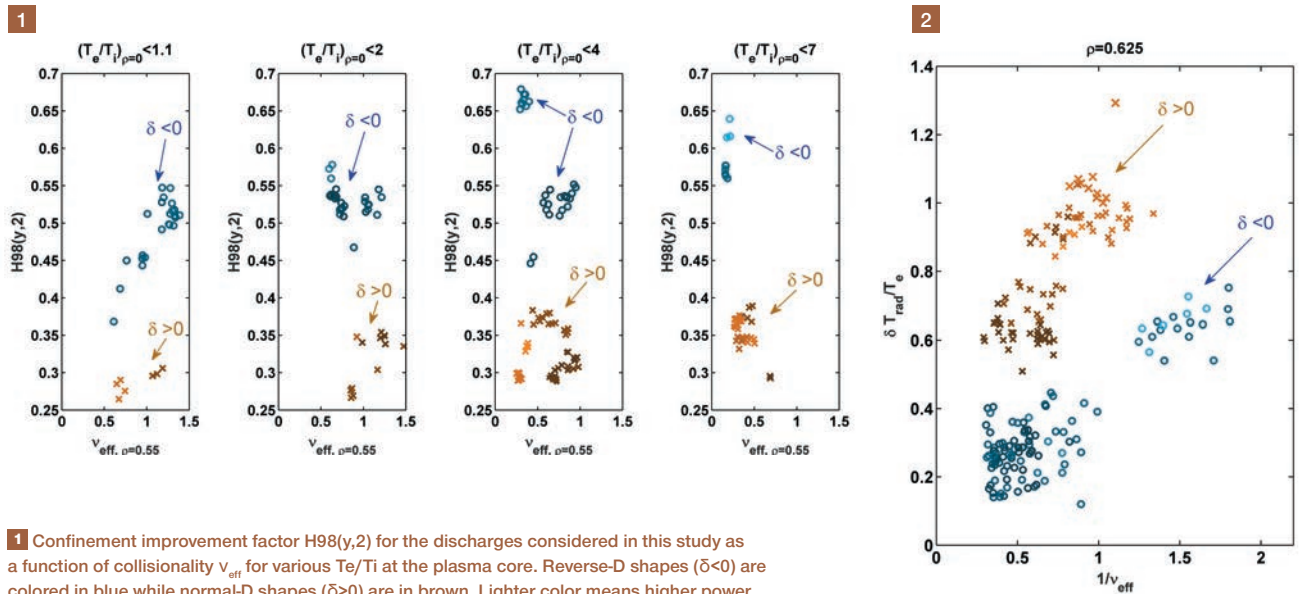

1 Confinement improvement factor $H98(y,2)$ for the discharges considered in this study as a function of collisionality ν_{eff} for various T_e/T_i at the plasma core. Reverse-D shapes ($\delta < 0$) are colored in blue while normal-D shapes ($\delta > 0$) are in brown. Lighter color means higher power.

2 Relative radiative temperature fluctuations as a function of the inverse of collisionality $1/\nu_{\text{eff}}$. (Colors same as in Fig.1.).

TCV Diagnostics



Plasma diagnostics are the scientists' eyes and ears in observing the experimental behaviour of the plasmas we are investigating. As such, on an exploratory machine such as TCV, these diagnostics are under constant evaluation and improvement as technology or experimental need provides or requires. Although there are many, highly interesting, diagnostic systems that probe very specific plasma behaviours, there is a base class of diagnostics that measure general plasma parameters such as the temperature and density profiles of the electrons and ions, plasma position within the TCV vessel and plasma radiated power. With the TCV upcoming divertor upgrades, these staple systems must not only be maintained but also modified to suit the upcoming requirements. Dr **BASIL DUVAL**, MER, is the leader of this research line and exposes below what were the main achievements in 2017.

Upgrades have been made to the TCV Thomson Scattering laser probe of electron density and temperature. Here, a bright laser is shone through the plasma and photons absorbed and re-emitted by the electrons are analysed by an array of spectrometers whose lines of sight intersect the laser trajectory (**Figure 1**). Upon re-emission, the photons have acquired the starting velocity of the target electrons such that an analysis of their spectral distribution, in terms of Doppler shifts reveals the velocity and density distributions of those electrons. With strong electron heating from our X2 and X3 gyrotron and heating and some extra degree of direct electron heating from the installed and upcoming neutral beam injectors, the electron's kinetic profiles are of strong interest. Furthermore these measurements allow us to estimate the temperature and density gradients in the plasma that are fundamental in determining the most active turbulence mode underlying enhanced energy transport.

For the planned future divertor upgrade, two major systems were enhanced. The spectrometer chord density was increased by the addition of over 80 new spectrometers. This was accompanied by new optical fibre mounts (**Figure 2**) that permitted the fibres, and hence their image in the plasma, to be closer, increasing the available spatial resolution to 6mm in the divertor and 12mm in the core region. In view of the large divertor region at relatively low temperature associated with the upgrades, a modification of the spectrometers to measure temperatures as low as 1eV was investigated. A new interference filter set design was examined for a new batch of 20 "low temperature" spectrometers that will view the existing laser line of sight through the divertor and should achieve a low temperature limit (determined by detector noise or signal strength) of about 1eV, which is a major achievement for such a system. These spectrometers are designed and built at the SPC and will be further integrated into the TCV real-time control system such that the measured temperatures can be employed, during the progression of a single discharge, to modify the plasma and divertor performance (**Figure 3**).

1

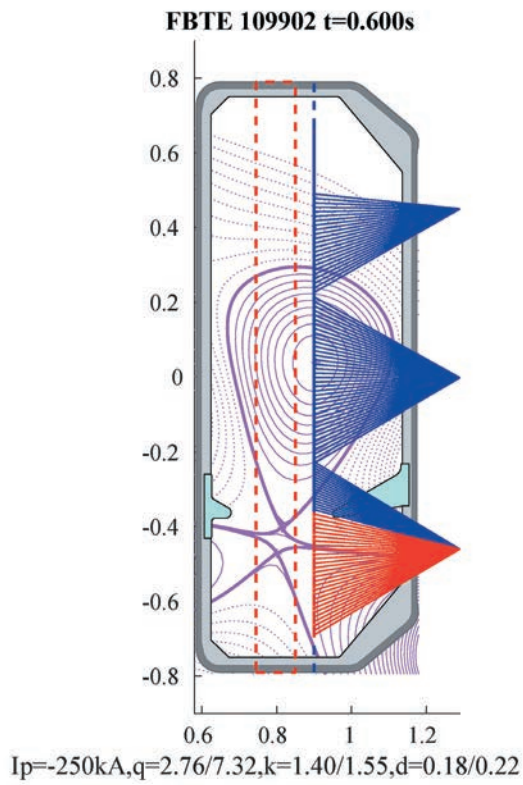

2

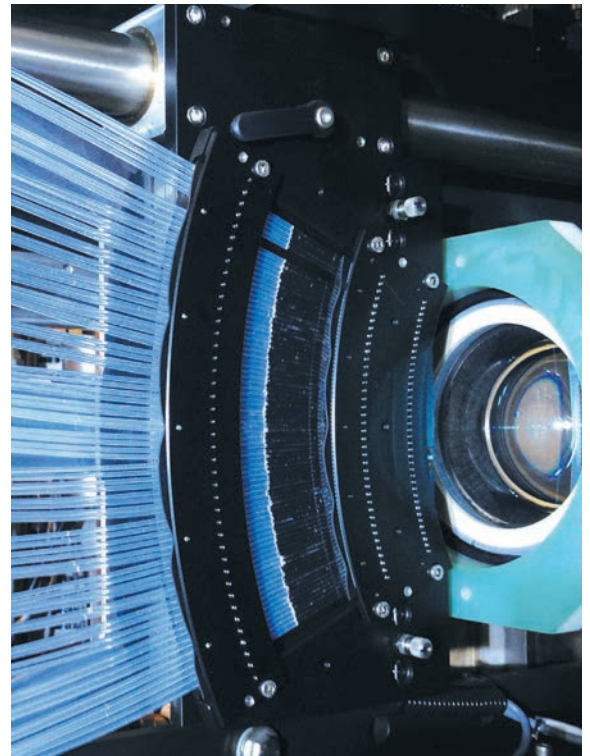

3

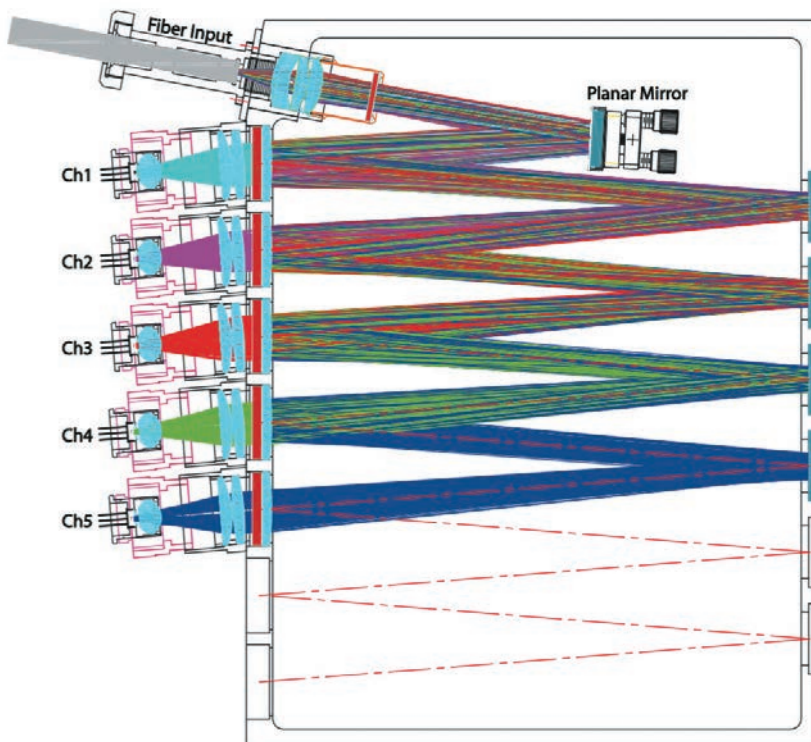

1 Poloidal cut of TCV vessel showing the vertical laser trajectory and the presently installed chords in blue. The red chords indicate the position of the new divertor low-temperature chords in development.

2 Photograph showing the new optical fibre holder system. This aligns the fibre laterally so that they intercept the laser beam through the plasma thus providing information for a range of plasma positions that can then be re-cast as an electron temperature and density profile.

3 Picture of the SPC designed spectrometers where up to 5 filters are used to distribute the light spectrally between 5 Avalanche Photodiode Detectors. The signal ratios are sensitive to the electron temperature and their amplitudes to the electron density.

TCV Heating



A variety of methods for heating a magnetized plasma are presently being used in Tokamaks, from irradiating it with neutral high-energy particle beams (NBI, Neutral Beam Injection) to exposing it to high-power radio waves at frequencies chosen such as to match one of the natural modes of oscillation in the plasma, where the waves can then be absorbed, such as Electron Cyclotron Waves (ECW). The TCV Heating research line is led by Dr **STEFANO ALBERTI**, MER. It includes both ECW and NBI and its activities are described below.

TCV ELECTRON CYCLOTRON HEATING SYSTEM AND ITS UPGRADE

The use of millimeter radio waves at the highest normal mode frequencies, the electron cyclotron waves (ECW), has the potential to very locally deposit energy and eventually control instabilities of a fusion plasma as well as heating it. An additional advantage is that ECW propagate seamlessly from free space to the plasma with no regions of evanescence, which significantly simplifies the launching system (the “antenna”).

The ECW are generated by a coherent source, known as gyrotron, capable of producing more than a megawatt radiation at frequencies typically ranging from 80GHz up to and even in excess of 200GHz, as foreseen for a future device such as DEMO. Gyrotrons belong to the family of coherent radiation sources based on intense electron beams. The physical mechanism of a gyrotron is based on the relativistic dependence of the electron cyclotron frequency on the electron kinetic energy and an associated instability known as the “negative mass instability”.

TCV EC-system upgrade with two 1MW/2s dual-frequency 126/84GHz gyrotrons including two new top-launchers

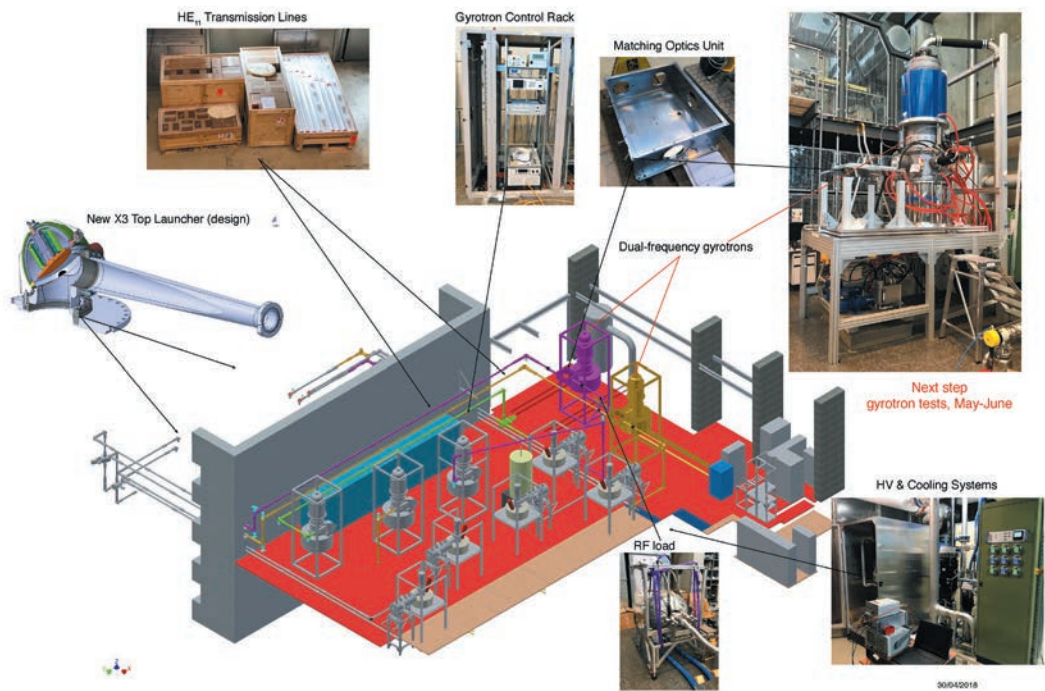

TCV EC-system with dual-frequency gyrotrons included. Depending on the frequency generated (126 or 84GHz), the mm-wave radiation is directed via the Matching Optics Unit towards the corresponding existing transmission lines for top-launch (X3@126GHz) or low-field-side launch (X2@82.7/84GHz or X3@118GHz). The insets showing the first dual-frequency gyrotron with different gyrotron auxiliaries: control and protection units, High-Voltage and cooling systems, Matching Optics Unit, high-power calorimeter (rf load), the transmission lines and the design of the X3 top launcher.

During the last two decades, SPC has been very active in the physics and technology of electron cyclotron heating (ECH) systems from the source (gyrotron) to the plasma, in developing and exploiting the ECH system for the TCV tokamak, but also, via international collaborations, in the development of ECH systems planned on ITER and DEMO.

Several decades of intensive R&D activity on theory, experiment and industrial development were needed to develop a state-of-the-art gyrotron meeting all the necessary requirements for the presently operated fusion devices and in particular for ITER. In Europe this effort is carried out by the EGYC consortium in which SPC is one of the main actors. The present dominant activity within EGYC, together with the industrial partner, the French company Thales Electron Devices (TED), is devoted to the industrialization of the gyrotron for a series production in view of providing the electron cyclotron heating system of ITER. In parallel to this activity, EGYC is pursuing R&D aimed at significantly increasing the unit power as well as the frequency in view of the future demonstration power plant DEMO.

The ECH system on TCV has been very successfully operated for more than two decades and has been realized, in its main parts, based on the scientific and technological expertise established at SPC. This activity was also supported by collaborations with the EGYC partners.

The ongoing upgrade of the TCV EC-system includes two additional MW-class dual-frequency gyrotrons (84 or 126GHz/2s/1MW) each equipped with a dual-frequency matching optics unit (MOU), which redirect the ECW towards the corresponding launchers for second (X2) or third harmonic (X3), X-mode plasma heating. The dual-frequency gyrotrons have been designed based on numerical models developed at SPC and in collaboration with EGYC members. Using state-of-the-art technology, they are being manufactured by TED. With the aim of simplifying the main entry in the TCV vessel, a new launcher for the X3 heating is foreseen. The MOU and the X3-launcher have been designed in-house and will be manufactured at SPC using a state-of-the-art 5-axis milling machine. The complex system integration in the TCV global system has been fully designed, manufactured and is being commissioned.

The upgraded ECH system will be operational in the 2nd half of 2019.

NEUTRAL BEAM POWER INJECTION ON TCV

TCV has continued the strategic task of adding direct ion heating to complement the strong electron heating provided by the gyrotrons. The first 1MW 25keV beam was installed in 2015 and has successfully heated the ions and injected tangential momentum into TCV plasmas more than tripling the ion temperature and resulting in a fivefold increase of the toroidal rotation velocity. For higher plasma densities and fast ion studies, a second 1MW 50keV beam is being procured. This beam also injects tangentially but opposite to the existing beam permitting balanced momentum injection. A range of fast ion diagnostics is also planned, with Neutral Particle Analysis (NPA), Fast Ion Dalpha Spectroscopy (FIDA) and Fast-Ion Loss Detection (FILD) already being procured.

Heating beam with tangential injection into the TCV tokamak

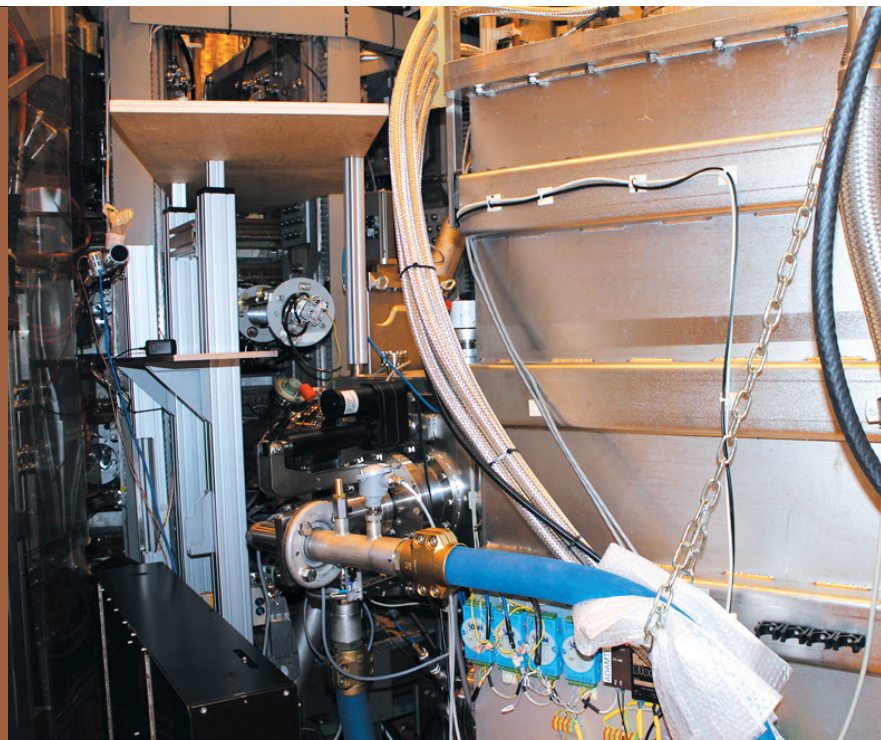

TCV Boundary



The TCV Boundary Group is led by Prof. **CHRISTIAN THEILER**. He explains us below what the main objectives of his group are, and what were the notable achievements in 2017.

The tokamak boundary plasma needs to assure adequate confinement of the superhot, 100 million degrees centigrade fusion core without damaging the surrounding wall structures. By leveraging TCV's unique magnetic shaping capabilities and excellent diagnostics accessibility, the Boundary Group works on advancing the fundamental understanding of the complex, turbulent boundary plasma and developing improved solutions for a reactor.

The most promising way to limit the heat flux to the wall structures surrounding the fusion plasma is to operate in a detached regime, characterized by a cold plasma near the wall and reduced plasma-wall contact. Access to a detached regime is facilitated by increased transport across magnetic field lines, high density, and the controlled addition of impurity species such as nitrogen. Unfortunately, there is a fine line between efficient protection of the wall by a detached plasma and adverse effects on the performance of the fusion core. Over the past few years, it has become ever clearer that alternative magnetic geometries of the boundary plasma have a large potential to address these critical issues.

In 2017, recent studies of detachment characteristics in the most promising alternative geometries in TCV low-confinement (L-mode) plasmas have been extended to the more challenging and reactor-relevant high-confinement (H-mode) plasma operation. H-mode was successfully achieved in all the alternative geometries with little difference in access conditions and H-mode characteristics. Signs of detachment have been demonstrated in these plasmas, pathing the way to explore its dependence on geometry and experimentally verifying predicted benefits. In parallel, a better fundamental understanding of the detachment process in L-mode plasmas has been achieved through novel spectroscopic techniques and comparison with modeling. The dependence of cross-field transport on magnetic geometry could also be elucidated in the experiment and partly reproduced in turbulence simulations, identifying clear benefits in particular in so-called Snowflake and "long-legged" configurations.

In the coming years, TCV will undergo substantial enhancements to further contribute to the development of a viable tokamak boundary solution. At the heart of these activities is the installation of physical barriers in TCV. These barriers will increase the density of neutrals and impurity species in the region of plasma-wall contact, which is key for detachment in high power plasmas. The design of these barriers, optimized for best performance while being resilient to the heat fluxes and electromagnetic forces during normal and off-normal operation, is close to being finalized. For optimal physics exploitation, the diagnostics coverage of the boundary plasma is being increased substantially with novel diagnostic systems developed at the SPC workshop and in collaboration with external collaborators, in particular from MIT, UCSD, DIFFER, and the University of York.

SHAPING THE PLASMA TO REDUCE THE POWER LOAD TO THE WALLS



Research carried out by **Roberto Maurizio**, PhD student at SPC under the supervision of Dr H. Reimerdes, has reached important milestones in 2017. The central theme of this research is the investigation of how the power leaving the main hot plasma reaches the wall, and, more specifically, how we can possibly act on this by operating the tokamak in different, novel configurations.

In the conventional *Single-Null* magnetic configuration, shown in Figure 1, the heat and particles leaking from the superhot plasma impact on the machine walls at two distinct locations, known as *strike points*. In the alternative *Low-Field-Side Snowflake Minus* magnetic configuration, shown in Figure 2, the addition of a secondary X-point creates two additional strike points, and produces an extended region, between the X-points, where the magnetic field is almost purely toroidal. This results in an increased magnetic field line length, which is beneficial for volumetric power losses and therefore could *play a key role in reducing wall heat fluxes*. These attractive power exhaust properties make the Snowflake a possible candidate for a nuclear fusion reactor.

A recent study on TCV provides evidence that cross-field transport is substantially enhanced in the intra-null region of the Snowflake. In this study, the deposited heat fluxes at all four strike points have been measured by an infrared thermography system. These measurements were performed for increasing spatial distance dr_{x2} between primary and secondary separatrix, shown in Figure 2 in blue and red respectively. Then, the variation of the power measured at SP4 with the separatrix distance, shown in Figure 3, is compared to a simple model to extract the width of the heat flux exhaust channel in the intra-null region. The observations point towards a local enhancement of the *effective cross-field diffusivity*, i.e. the strength of perpendicular transport, which imply an important benefit of the Snowflake geometry, but also give new insights into the dynamics of cross-field transport in general.

1 The Single-Null magnetic configuration, with the inner (ISP) and outer (OSP) strike points.

2 The Low-Field-Side Snowflake Minus magnetic configuration, with four strike points and two x-points.

3 Measured variation of the power reaching the strike point SP4 when the spacing between the separatrices dr_{x2} is increased and interpretation based on a simple heat transport model.

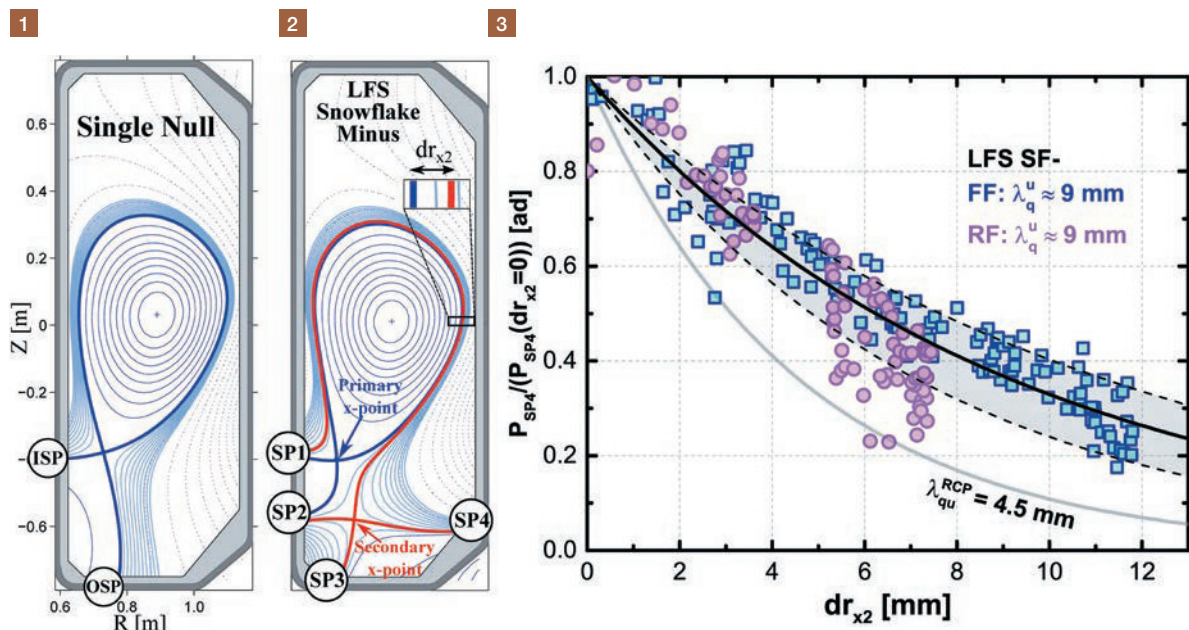

Theory and Numerical Simulation



The Theory and Numerical Simulation group at SPC is headed by Prof. **PAOLO RICCI**. He explains us the main motivations behind the activities of his group:

The main goal of the theory group at SPC is to make progress in the understanding of the plasma dynamics in magnetic confinement devices for fusion. Our research is based on first-principles and has the double perspective of providing an interpretation of the experimental results from current fusion experiments (*postdiction*), but also to make true predictions about future experiments. The equations governing the plasma dynamics are too complex to be solved analytically, and therefore we are heavily relying on numerical simulations. The theory group has very close ties with the TCV group, with a vigorous activity of modeling and interpretation of experimental results.

In 2017 the activities of the SPC theory group have focused on the analysis of global instabilities that affect the tokamak plasma, 3D magnetic configurations, and the interaction with fast particles. First principle based simulations of plasma turbulence in the core and periphery of fusion devices were performed, following important progress in the development of model and simulation tools, and shedding light on some turbulent processes at play in tokamaks. Activities on real-time simulations and predictions, pioneered by the SPC, continued. Some highlights are given below.

ON GLOBAL INSTABILITIES AND 3D CONFIGURATIONS

Even though tokamaks are designed to have an axis of symmetry, sometimes this symmetry is spontaneously broken. This is the result of an instability that develops and saturates at finite amplitude. Our group has pioneered the analysis of this final state from the point of view of 3D equilibrium theory. To this end, we deployed a code ordinarily used for studying the plasma equilibrium in stellarators* to model equilibria in tokamaks that present a 3D structure. This 3D equilibrium approach was verified with analytic nonlinear solutions of pressure and current driven external instabilities.

ON IMPURITIES

Another “hot topic” in fusion research is the problem of impurities, i.e. ion species distinct from the hydrogenic ions that constitute the fuel. The presence of impurities in the plasma core is detrimental for two main reasons: it dilutes the fuel species and enhances energy losses by radiation, with both effects resulting in a decrease of fusion power. The fast ions (helium) that result from the fusion reaction, on the other hand, need to be confined long enough so as to give back their energy to the fuel species. We have made several advances in the modelling of fast particle and impurity transport. Our research has focused on the effect of global instabilities in the presence of the symmetry-breaking modes mentioned in the previous paragraph.

ON TURBULENCE

Turbulence is known as the main limiting factor for the quality of magnetic confinement. We are constantly working on refining the physical models that describe various types of turbulence in our simulation codes. Adding more physics, however, can result in intractable complexity and, for practical purposes, we are often forced to find compromises between a full physics description and a reasonable time-to-solution. An example is the so-called “hybrid” electron model that has been successfully introduced in one of our flagship codes, ORB5, which can describe certain classes of electron-driven turbulence simultaneously with ion-driven turbulence, while saving computing resources by at least one order of magnitude as compared to standard kinetic electron models.

Similarly, the simulation of the plasma dynamics at the tokamak periphery, while remaining a crucial issue on the way to fusion energy, is made particularly challenging by the multiphysics nature of this region, and the lack of a proper model that can represent the different collisionality regimes within a reasonable computational cost. In 2017, we significantly advanced the development of a proper description for the tokamak periphery. A drift-kinetic model was developed that can represent plasma at low collisionality and, in the high collisionality regime, reduces to a fluid model. We expect this model to be a considerable step forward in the simulation of the tokamak periphery.

Thanks to our numerical simulations, significant progress was made in the understanding of core tokamak plasma turbulence. One of our studies, using the GENE code, revealed a measurable effect of plasma shaping on the turbulent transport of momentum. More precisely, we examined plasma shapes that break the mirror symmetry. Using these numerical results, we could design TCV experiments, which were then carried out and could be successfully compared to our theoretical predictions. In another study, we could use our simulation results to reduce the uncertainty on physical parameters, therefore allowing closer comparisons between experiments and theory.

ON DISRUPTIONS AND REAL-TIME CONTROL

Fusion tokamak reactors require high performance while avoiding any disruption limits. This can only be achieved with real time simulators run while the discharges are executed, which provides real-time physics information about the discharge evolution. In 2017 we further developed codes and models that can accurately predict and interpret tokamak radial transport phenomena and run faster than real-time in a fusion reactor. In this way one can predict ahead of time if the discharge will reach an operation limit and avoid it. This is used in present tokamaks for integrated real-time control and disruption avoidance studies.

- * A stellarator is an alternative way to confine plasmas in a torus with magnetic fields. In a stellarator, the helicity of the magnetic field, which is necessary to confine the charged particles of the plasma, is produced by deforming the magnetic field shape using external coils, and not by inducing a strong current flowing in the plasma as is the case for tokamaks. In a stellarator, due to this deformation, the toroidal axisymmetry is necessarily broken, hence the term '3D' characterizing these configurations.
- ** PASC = Platform for Advanced Scientific Computing, a structuring project supported by the Federal Council for the ETH Domain, whose overarching goal is to position Swiss computational sciences in the emerging exascale-era.
- *** GPU = Graphics Processing Unit, used as an accelerator in High Performance Computing.
- **** Fusion triple product: is the product (density) x (temperature) x (confinement time). It is used to quantify the performance of a given plasma experiment. In order to achieve sustainable fusion, this triple product must exceed a given value.

NUMERICAL SIMULATIONS AND HIGH PERFORMANCE COMPUTING (HPC)

To get insight into the plasma dynamics state-of-the-art scientific codes are necessary, based on a first-principles approach. The simulations carried out by the group are performed on some of the most powerful computers worldwide. Tens of millions of CPU-hours were allocated to projects led by SPC theory group members; we mention, among the HPC platforms used by the group in 2017, the Marconi-Fusion computer at CINECA, and the Piz Daint computer (the fastest in Europe and the third worldwide) at the Swiss National Supercomputing Centre (CSCS). In order to tap the increasing power and complexity of these platforms, major code refactoring is sometimes necessary. In 2017, in part thanks to the support of the PASC initiative**, a major effort has been put on the ORB5 code, which simulates turbulence in the core of tokamak plasmas. An increased level of parallelism, algorithmic changes and data restructuring resulted in a performance increase by a factor of about 2. New architectures such as GPU***-equipped computing nodes have also been addressed, which have the potential to further reduce the time-to-solution by important factors for our application code ORB5.

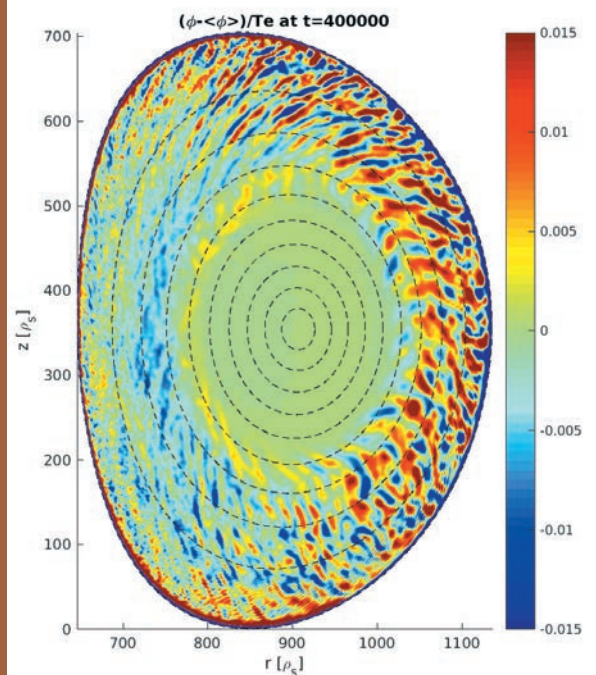

MODELLING ICRH IN 3D PLASMAS



Dr **Jonathan Graves**, MER, is a senior scientist in the theory group of SPC. With his team of PhD students and post-doctoral associates he explores the fast ion generation by RF waves and Neutral Beam Injection (NBI) and their confinement properties in 3D configurations.

The groundbreaking new Wendelstein 7-X stellarator* has recently commenced operation, in Greifswald, Germany. While it has already broken the world record into the fusion triple product**** in a stellarator, it awaits new auxiliary ion heating systems. One such system is ion cyclotron resonance heating (ICRH), the implementation of which will heat the core plasma further, but more crucially should test whether the advanced stellarator approach towards a fusion reactor can confine fast ions such as alpha particles resulting from the fusion process. The modelling of the wave-particle interaction required in these strongly three-dimensional magnetic fields is extremely challenging. At SPC we have developed the SCENIC ICRH package, uniquely equipped for the modelling of most ICRH schemes envisaged in W7-X. The intrinsically 3D structure of the electric field produced from the ICRH antenna is shown in Figure 1. We have recently deployed a method of exploiting the 5-fold periodicity of the W7-X device to significantly improve the resolution of the simulation for the same memory requirements. Another advance is the deployment of a so-called “5 1/2D” model for the description of ion orbit-following and wave-particle interaction in a time-varying electromagnetic field. The method combines the advantages of previously known methods: it has the speed of less accurate 5D models and nearly the precision of complete 6D models.

Stellarators have very high density in comparison to similarly sized tokamaks, and as such the collisionality of stellarators makes it difficult to produce a superthermal population from ICRH. Our main finding was to show that it is possible to generate such populations with so called 3-ion schemes. In Figure 2, it is shown that 3-ion schemes produce improved heating to the plasma as compared to standard minority heating schemes. It is seen that the proposed NBI heating scheme also produces reasonable core heating, but new simulations recently performed demonstrate that it is possible to further energise NBI ions with ICRH, with the dual advantage of highly core centered heating and the generation of super-thermal ions.

1

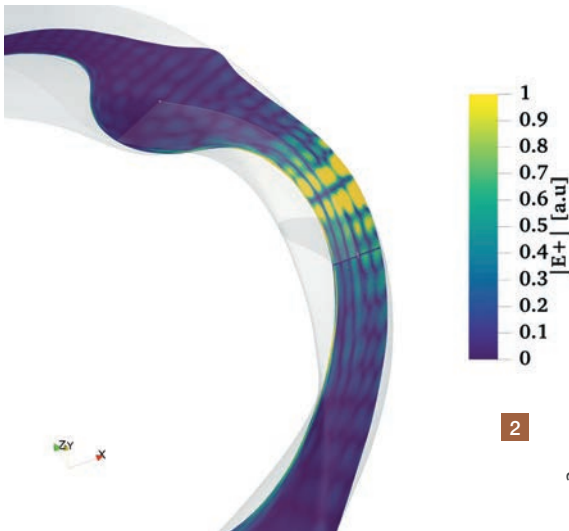

1 ICRH wave left-handed electric field component in the W7-X stellarator. Computed by the global full wave 3D finite element code LEMAN, part of the SCENIC package.

2 Power density as a function of plasma radius ρ , for various heating schemes proposed in W7-X. This shows the superiority of the new 3-ion ICRH scheme over the standard minority ICRH. It also shows a synergetic effect of the combined application of RF and Neutral Beam Injection (RF-NBI).

2

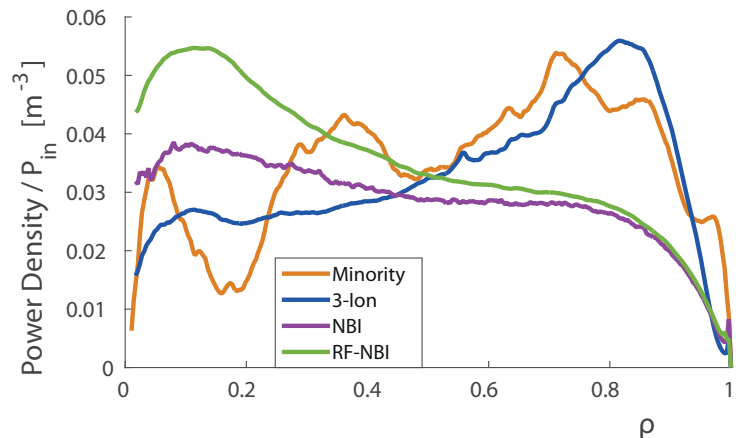

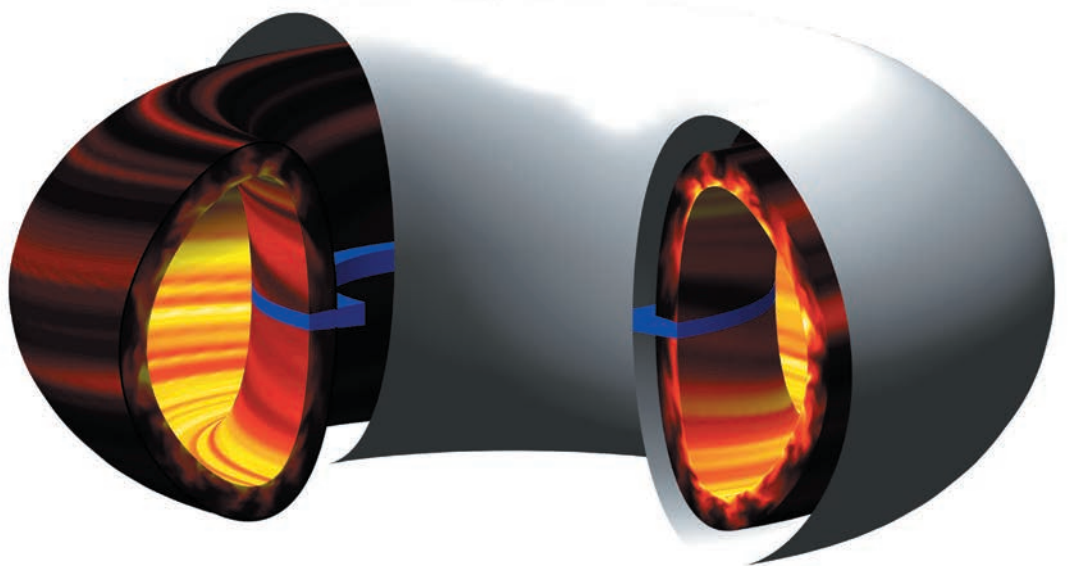
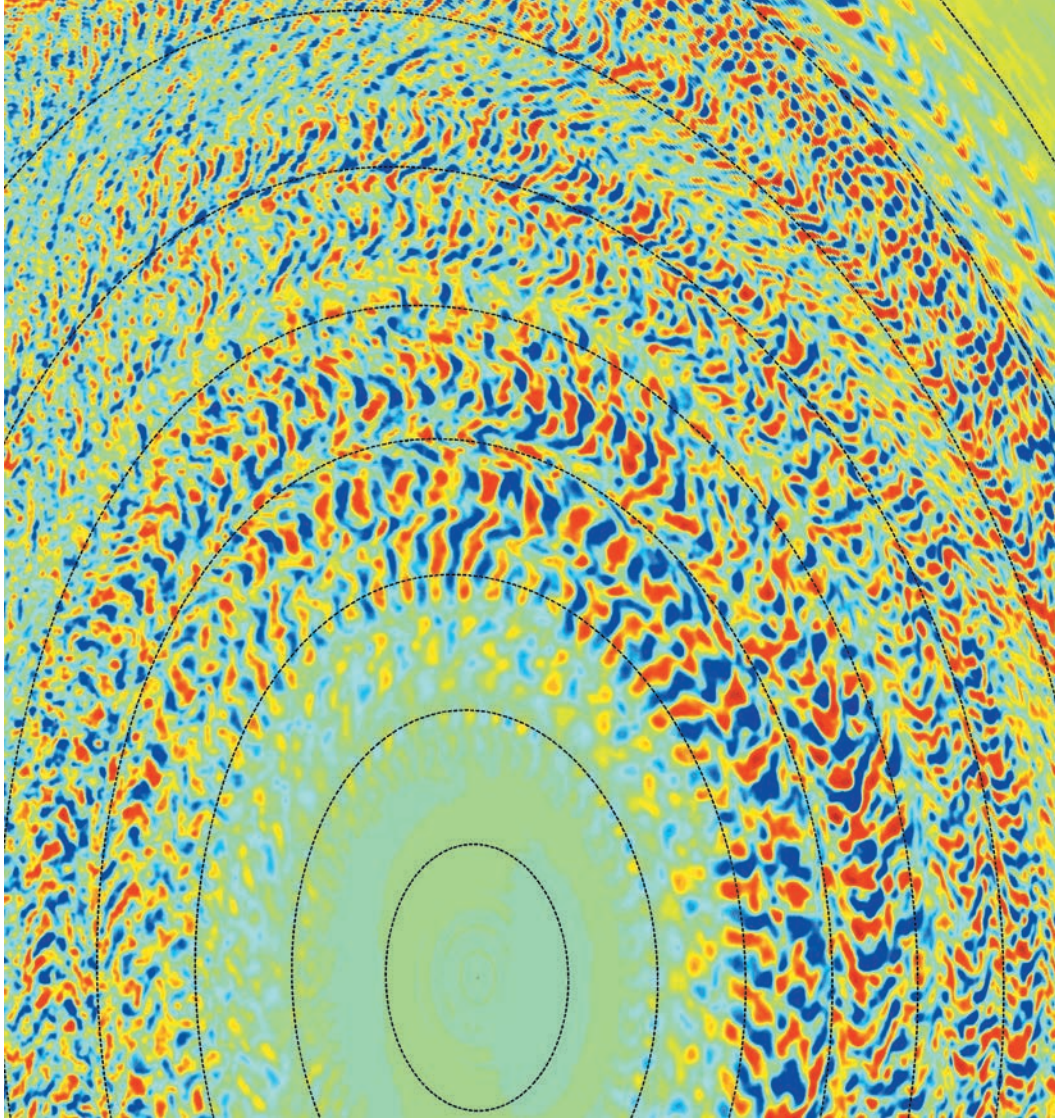

Basic Plasma Physics and Applications



In 2017, Dr **IVO FURNO** was named EPFL Adjunct Professor. He is heading the Basic Plasma Physics and Applications group, whose activities are focused on two topics. First, plasma turbulence in magnetized

plasmas of relevance for fusion is studied on the TORoidal Plasma EXperiment (TORPEX) device. Second, the development of a novel negative ion source for Neutral Beams is being carried out on the Resonant Antenna Ion (RAID) device. Combining a full set of plasma diagnostics together with theory and numerical modeling we advance the basic understanding of the underlying plasma phenomena to a level where quantitative comparison between theory and experiments are possible.

FAST IONS ON TORPEX

In fusion plasmas, fast ions from fusion reactions, ion-cyclotron heating or neutral beams have long been a center of interest since their turbulent transport can affect energy deposition and plasma heating. In TORPEX low temperature plasmas, these fast ions are generated by a Lithium source and detected after propagation through the turbulent plasma. Our research focused on studies of intermittence in detection signals of fast ions. A comprehensive set of experiments showed that the signal statistics varies with the detector location, even in the same fast-ion transport regime. These observations suggest that the degree of intermittence, as measured with time-series skewness, may not be an indicator of a particular transport regime. A theoretical model was developed to explore the relationship between different time-series statistics.

FLUORESCENT PROBE ON TORPEX

TORPEX has excellent coverage of Langmuir probes, which enables the determination of transient plasma structures with great temporal resolution. However, the spacing between probes limits the spatial resolution, thus preventing us to observe fine scales structures of interest. To resolve small spatial features, we developed a novel diagnostics based on a cathodoluminescent screen that emits light when struck by plasma electrons. A first series of tests showed the feasibility of this method of detection for increased spatial resolution.

RAID

Neutral Beam Injectors (NBIs) for future fusion devices will be based on negative deuterium ions and will have to fulfill high standards in terms of spatial uniformity of the beam, operate in

continuous mode (CW), and minimize the co-extracted electron current. On RAID, we explore the possibility to use bird-cage resonant antennas as helicon plasma sources to produce negative ions in the next generation NBIs. In 2017, we demonstrated stable operation in both hydrogen and deuterium for working nominal conditions. Using optical emission spectroscopy together with a collisional-radiative code, we show promising results in terms of negative ion production, reaching negative ion densities of relevance for future applications, dissociation degree and favorable scaling with injected radio-frequency power.

BIOLOGICAL APPLICATIONS OF NON-THERMAL PLASMAS

Non-thermal plasmas, i.e. ionized gases that are out of thermodynamical equilibrium, can be used for biological applications such as food decontamination, plasma medicine, environmental remediation and plasma agriculture, a rapidly emerging field. In 2017, we have started equipping a new laboratory at SPC, called bio-plasmas laboratory, which will explore the huge potential of non-thermal plasmas in a variety of societal applications. Three projects have already started: in collaboration with the University of Lausanne, we investigate the mechanisms governing plasma-seed interactions. Within an InnoSuisse project and in collaboration with FELCO SA, the Ecole d'Ingénieurs de Changins and HES-Yverdon, we are developing a plasma-based sterilizer to treat plants contaminated by infectious bacterial diseases. Together with ETH Zurich and in collaboration with the SPC spin-off company Helyssen Sàrl, we are developing high-pressure antennas for food and powder treatment.

INDUCTIVELY-COUPLED PLASMA USING A PLANAR RF RESONANT ANTENNA FOR SOLAR CELLS

In the photovoltaic industry, fast deposition of silicon tends to form porous films, which consequently suffer from post-oxidation on exposure to air, resulting in poor quality photovoltaic material. At SPC, it was shown that post-oxidation can be suppressed using large-area inductive sources provided that RF substrate bias is applied to control the ion bombardment energy. This enhances the surface mobility of radicals, thus compacting the growing film.

HUMAN PROSTHESIS

Advanced materials for human prosthesis require the development of new technologies to improve barrier properties of protective thin films. In collaboration with COMELEC SA in the framework of an InnoSuisse project, the SPC develops a high barrier SiO₂ coatings using PECVD (Plasma Enhanced Chemical Vapour Deposition) with a large volume plasma source (bird cage antenna) and explores the limits of SiO₂ thin film conformity on high aspect ratio samples. By optimizing the ion bombardment at different bias voltages, the barrier properties of the SiO₂ thin films were improved by a factor 100.

1

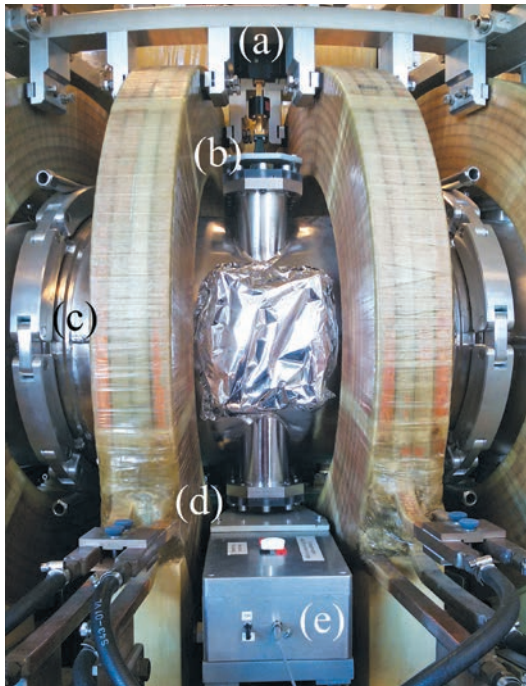

3

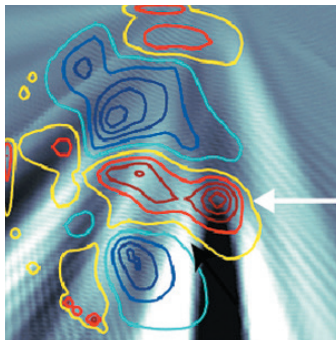

1 Microwave system installed in TORPEX. (a) microwave source; (b) microwaves are injected on top; (c) TORPEX vessel and toroidal magnetic field coils; (d) microwaves exit on the bottom; e) detector.

2 Experimental setup in TORPEX (a). Snapshots of measured density fluctuations (b)(c)(d) obtained from an array of Langmuir probes. The pink shaded area represents the mmw beam.

3 Numerical simulation of the beam scattering (levels of grey) by turbulent density fluctuations (colored contours).

2

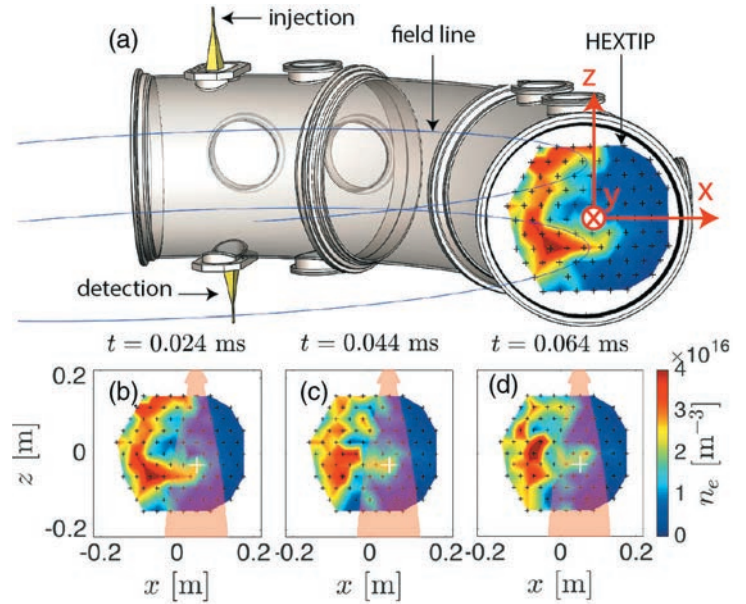

TURBULENT SCATTERING OF MICROWAVE BEAMS



Oulfa Chellai, PhD student at SPC, supervised by Prof. Ivo Furno and Dr Tim Goodmann, obtained the Best Student Poster Award at the 2017 International Conference on Radiofrequency Power in Plasmas. She explains below why her research is crucial for fusion.

High-power microwave sources at the electron cyclotron frequency are an essential feature of the ITER design. They can be used to heat the plasma, to drive plasma current and also to control certain instabilities, called neoclassical tearing modes, which can be responsible for core confinement degradation. For that purpose, a narrow millimeter beam will be targeting the plasma core with a surgical precision. When entering the plasma, the beam will traverse a turbulent plasma layer with strong fluctuations of the electron density, called “blobs”, acting to scatter the beam. This could result in a decrease of efficiency in the use of microwaves.

A European collaboration was initiated in the frame of the Enabling Research Programme of EUROfusion to study this effect. On TORPEX, with a dedicated experimental setup, we have shown the first direct experimental measurements of the scattering of a millimeter-wave beam by plasma blobs in a simple magnetized torus. A first-principles full-wave model predicts fluctuations of the millimeter-wave power that are in agreement with experiments. These groundbreaking results have been published in Physical Review Letters.

Similar experiments were run on the TCV tokamak. The turbulence at the edge of the device was identified as being responsible for the fluctuations of the millimeter-wave beam power. A numerical effort is under progress using the GBS turbulence code to simulate the beam propagation in the turbulent plasma of TCV and reach predicting capabilities for ITER.

Applied Superconductivity

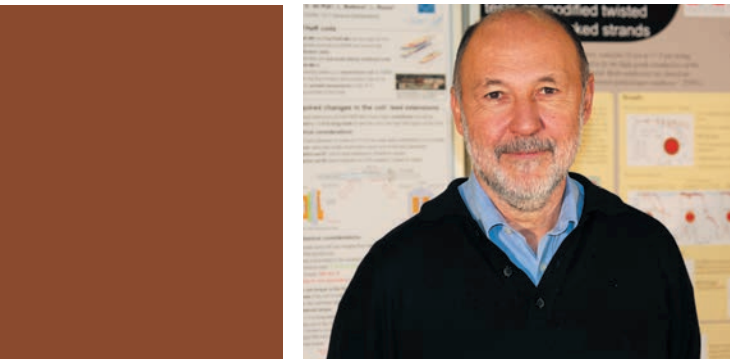

Based on the site of the Paul Scherrer Institute in Villigen, the activities of the Applied Superconductivity group are focused on design studies, R&D and testing for magnet technology. Both Low-Temperature and High-Temperature Superconductors (LTS and HTS) are investigated, with a primary focus on future fusion devices. The main experimental tool is the SULTAN test facility, a unique equipment that allows SPC to carry out tests of high current superconductor cables and joints, in particular for ITER and EUROfusion DEMO, recently also for CERN.

The Applied Superconductivity group is led by Dr **PIERLUIGI BRUZZONE**, who explains here what the main achievements of his group were.

DESIGN AND ANALYSIS OF THE SUPERCONDUCTING MAGNETS

The design of a high field (up to 17Tesla) Central Solenoid for DEMO have been completed, including mechanical and electro-magnetic analysis. The design of this “hybrid” magnet is described in more details on the next page.

The design and analysis of the Toroidal Field (TF) and Poloidal Field (PF) coil systems for DEMO has been updated, including the refinement of the layer grading in the TF winding pack, leading to a 20% reduction of the radial build.

DEVELOPMENT

The second prototype of DEMO conductor based on wind&react Nb_3Sn technology was tested with two samples (*More on wind&react vs react&wind: see separate text box*). The main objective was to develop a more efficient conductor than that of ITER, namely provide slightly better performance with lower amount of expensive Nb_3Sn material. Encouraging are the low AC losses and initial performance of the prototype, disappointing was the conductor degradation during long-term operation for the first sample. This, however, substantially improved for the second sample.

An InnoSuisse/KTI project for high-field solenoids made of HTS coated conductor tapes was successfully completed. This industrial R&D on smaller-scale magnets has an interesting potential to increase the magnetic field range in commercial magnets for laboratory and for nuclear magnetic resonance (NMR) used in research.

TESTING ACTIVITIES IN SULTAN

Tests of conductor samples and joints for the ITER magnets are an important task for quality control of ITER construction. This testing is a major task of the superconductivity group, occupying most of the SULTAN operating time. A specific testing action started in 2017 to address the cyclic loading degradation in the TF conductors, applying only a partial load.

Tests of LTS conductor samples and joints for DEMO, as well as the tests of a prototype HTS high current conductor (CORC) for particle detector.

For CERN, test of a prototype HTS dipole insert magnet made by a cable of coated conductors and wind&react Nb_3Sn joints for the accelerators of the Future Circular Collider (FCC).

The high-field fusion magnets are built from Nb_3Sn – an expensive material, whose crystalline structure is created by heat treatment at 650°C. After the heat treatment, also called “reaction”, the Nb_3Sn material becomes brittle. The designers of ITER decided to wind the Nb_3Sn conductors into coils, and heat-treat them in the final shape. The disadvantage of this **wind&react** technique is the “thermal strain”, i.e. the compression state of the superconducting wires in the coil, due to the different thermal expansion coefficients of Nb_3Sn and steel jacket of the conductor, respectively, which reduces the current-carrying capability of Nb_3Sn . On the other hand, in the **react&wind** method the Nb_3Sn cable is heat-treated before assembly into the jacket and wound to its final shape. In this way the thermal strain is drastically reduced and the performance of the conductor is enhanced. In large coils, with big bending radii, the brittle Nb_3Sn can withstand the necessary bending associated to the react&wind technique. Eventually, much less amount of Nb_3Sn strands is needed to carry the same electric current in the magnet.

HIGH TEMPERATURE SUPERCONDUCTORS CAN BE USED TO REDUCE THE SIZE AND COST OF A TOKAMAK FUSION REACTOR

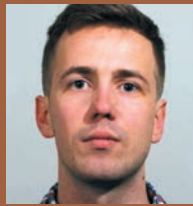

Research carried out by Nikoaly Bykovskiy, PhD student at SPC under the supervision of Dr Pierluigi Bruzzone and Prof. Ambrogio Fasoli, was instrumental in opening new perspectives for the design of tokamak reactors. The Central Solenoid (CS) is an essential component of the tokamak. Its main role is analogous to the primary of a transformer. It provides a large magnetic flux swing, which induces huge currents in the plasma, which plays the role of the secondary. Being placed at the heart of the device, it is exposed to very strong magnetic fields, and is also not easy to remove for maintenance, and thus has to be very reliable.

It is therefore a particularly challenging piece of equipment to design. In 2017, the Superconductivity group of SPC has achieved an important milestone by proposing a hybrid CS design for DEMO that looks very promising.

The proposed design aims to reduce the outer diameter of the CS for a requested magnetic flux. A more compact CS allows the reduction of the size of the whole tokamak, and consequently also a reduction of the overall manufacturing cost of DEMO. The generation of the same magnetic flux in a smaller CS leads to an increase of the magnetic field inside of the winding of the CS coil. The only superconductors that can withstand such a huge magnetic field are high-temperature superconductors (HTS).

Today, the cost of HTS is still significantly higher than that of low-temperature superconductors (LTS). In order to use the expensive material efficiently, the proposed CS is hybrid – the HTS, namely $REBa_2Cu_3O_{7-x}$ (RE = rare earth element), is employed only in the four innermost layers, where the magnetic field is highest, whereas the other 16 layers will be made of LTS, namely Nb_3Sn and $NbTi$, as illustrated in Figure 1. Because of the decline of the magnetic field from inner to outer radius of the winding pack, the superconductor cross section can be reduced in the outer layers. Also the amount of steel in the conductor jacket, which provides mechanical stiffness to the CS, can be reduced towards the outer radius.

The hybrid design reduces the outer radius of the CS by 15% (or 50 cm), compared to the reference DEMO design based on the Nb_3Sn technology. The peak magnetic field at the CS conductor is as high as 17.5 T, compared to 13.5 T in the ITER CS made of Nb_3Sn . A sketch of the 51 kA HTS conductor is presented in Figure 2. The current is carried by 12 strands of 7.2 mm diameter, which are wound around a central copper core. Each strand consists of 39 HTS tapes. Two 3 m long HTS conductor prototypes were already successfully manufactured and tested at SPC showing an initial performance in line with expectations. Measures to avoid conductor degradation during long term operation are subject of ongoing research and development.

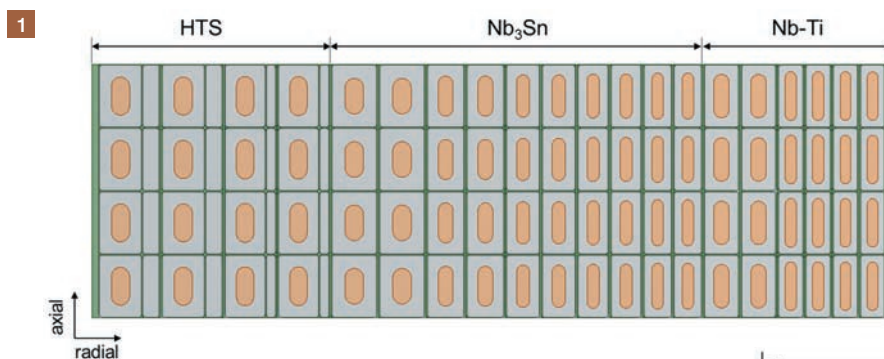

1 Layout of the four central conductor rows of the CS coil.

2 Sketch of the HTS conductor at highest field.

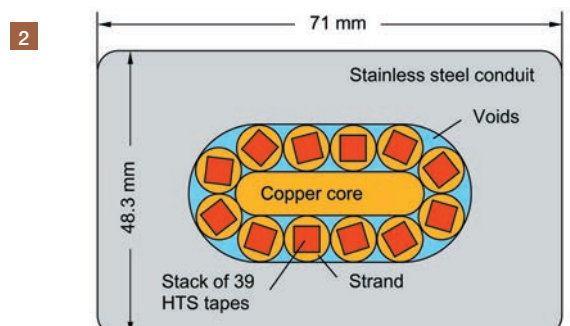

International Activities – ITER



The Swiss Plasma Center is embedded in a tight network of collaborations, not only at the European level, but also in the frame of worldwide projects, in particular ITER. Efforts, led by Dr **TIM GOODMAN**,

are mainly devoted to two main areas, namely the field of high power microwaves and the testing of superconductors for the coils (the latter is reported in the Section on Superconductivity).

The objectives of the international collaborations for ITER in the field of high power microwaves are twofold.

First, to design, test and verify the gyrotron for ITER developed by the EU. This gyrotron will operate at the frequency of 170GHz, have a power of 1MW, and a pulse duration of 3600s. Both design and testing are carried out by a consortium called EGYC, in which the Leading Laboratory is SPC. The gyrotron is manufactured by THALES. The testing is done at an ad-hoc facility at our premises.

Second, to design, test and verify components of the EC Upper Launcher (UL) for ITER. The design is carried out by the ECHUL consortium, in which Dr Jean-Philippe Hogge, MER, is the Deputy Project Leader for mm-wave design. The testing is carried out by SPC using a gyrotron supplied by Fusion For Energy (F4E, the EU ITER Domestic Agency) and purchased from GYCOM.

The EU ITER gyrotron was delivered to SPC following preliminary testing at our EGYC partner KIT (Karlsruhe, Germany) and the preparation of the SPC dual test facility. A second gyrotron tower was introduced to share all gyrotron subsystems. These were designed and tested in collaboration with F4E. The subsystems worked well during gyrotron testing. Both ITER-class gyrotrons were tested to near 0.8MW for nearly one minute and pulse lengths up to 300s at half power.

Components that require improvement to allow reaching 1MW and 3600s pulses have been identified, potential solutions have been proposed, and discussions with international partners continue with the goal to action solutions and extend systems operation in 2018.



The two gyrotron towers of the test facility at SPC. Both gyrotrons are ITER-class, 1MW, 1000s, 170GHz tubes, similar to those that will power one of the 8 beams of the ITER Upper Launcher, seen on the opposite page. The left one is the EU gyrotron manufactured by THALES, the right one is the gyrotron manufactured by GYCOM used to test components of the ITER Upper Launcher.

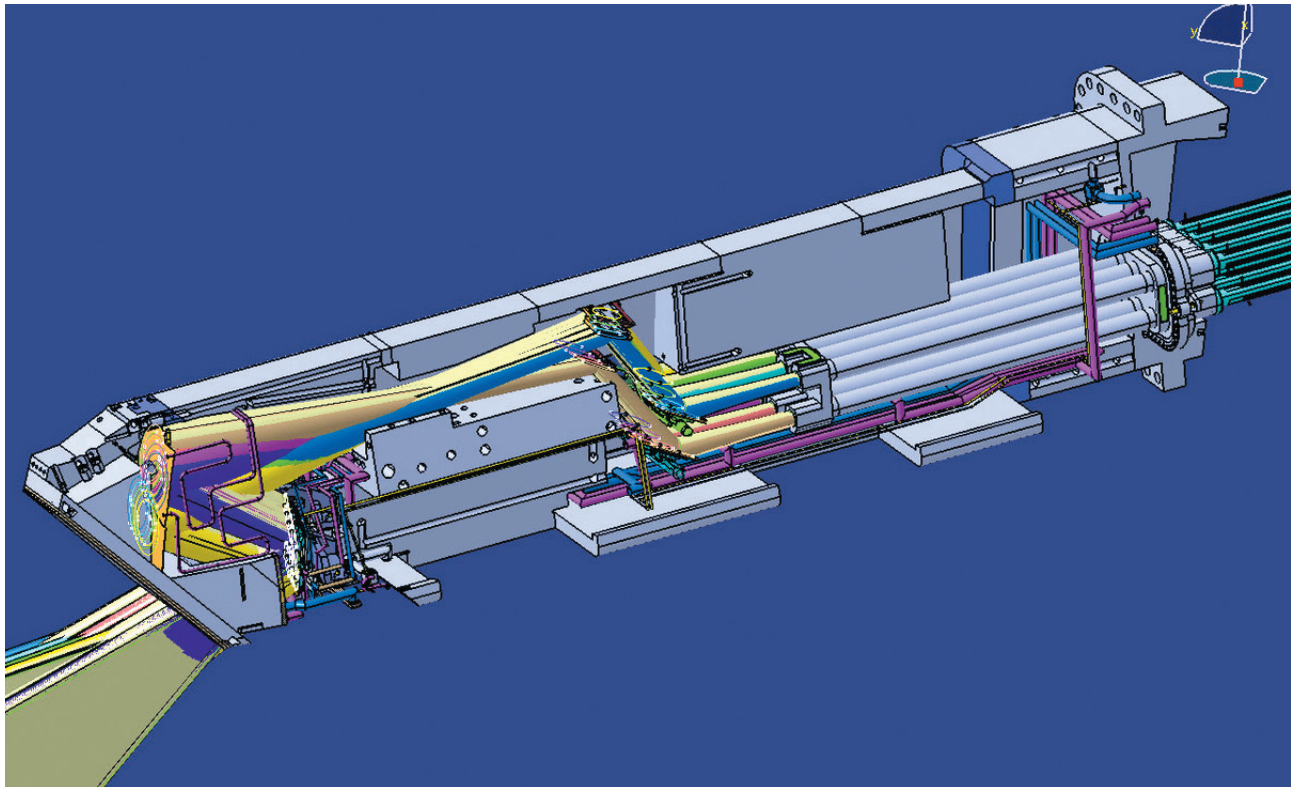

Sketch of one of four identical ITER Upper Launchers (UL) used primarily for a) plasma initiation of the ITER first plasma and b) stabilization of certain modes in the plasma. Two rows of 4 ex-vessel waveguides enter from the right through a double-closure-plate-subplate and continue, in-vessel, through neutron shielding to launch 8 mm-wave beams. Each beam reflects off of 4 surfaces before exiting the launcher (left); the last mirror can be rotated to aim at different locations in the plasma: there are two mirrors that steer the 4 beams of each row as a group; they have different steering ranges. The steering ranges can be seen as the fans on the left. The second and third mirror surfaces along the beam path are optimized to produce a narrow deposition location and strongly localized driven current channels in the plasma, while satisfying the strict spatial constraints within the launcher structure.

Plasma-wall Interactions



The Plasma-wall Interactions group at the University of Basel is headed by Dr **LAURENT MAROT**. He explains us the main motivations behind the activities of his group.

In the frame of plasma-wall interaction for ITER, a specific topic is studied: how to improve the lifetime of mirrors used to reflect the plasma light used for ITER's diagnostics. Deposits of beryllium and tungsten, from the ITER first wall, will indeed deteriorate the reflectivity of the mirrors. It is requested to clean these mirrors in the presence of a strong magnetic field, in vacuum conditions and without opening the reactor vessel. A mirror (blue rectangle in figure 1) was introduced in the EAST tokamak (China) at the first wall position with a remote handling manipulator. A cleaning procedure using a neon plasma was carried out in a 1.2 Tesla magnetic field. The characterization of the test samples (yellow dots in figure 1) revealed that the aluminum deposit (used to simulate beryllium contamination) was completely removed by ion sputtering. This successful test of in situ plasma cleaning of mirrors in a tokamak is a world first achievement and confirms the feasibility of this technique for ITER.

Illustration of the Edge Thomson Scattering mock-up mirror fixed on the MAPES manipulator and inserted in EAST. The exact position and angle (α) between the surface of the ETS mock-up and the magnetic field is shown in the inset (here $\alpha = 20^\circ$). The toroidal field is represented by the red arrow.

